OPERATION MANUAL

Model LET-1/2

December 2001



Far West Technology, Inc.
330 South Kellogg Ave, Suite D
Goleta, CA 93117

GENERAL INFORMATION

This instrument is manufactured in the United States of America by:

Far West Technology, Inc.
330 South Kellogg Ave, Suite D
Goleta, CA 93117-3814

Tel: 805.964.3615

Fax: 805.964.3162

Email: support@fwt.com

Web Site: www.fwt.com

Far West Technology has been manufacturing radiation measuring devices since 1972.

REPAIR SERVICE

Although we design and manufacture our instruments to a high standard, we realize that repairs are sometimes necessary. If you believe service is needed on this instrument please call our service department before shipping the instrument to us for repair; often we can help you with simple problems. If you do decide to return it to us for repair then please include:

1. Contact person's name
2. Organization or Company name
3. Address
4. Phone number of contact person
5. Description of the problem
6. Anything else you may think important

We will inform you of the repair charges and wait for your authorization before we repair your instrument.

TABLE OF CONTENTS

I. INTRODUCTION	2
II. PHYSICAL CHARACTERISTICS OF THE INSTRUMENT	2
III. FILLING THE INSTRUMENT WITH GAS	3
IV. ELECTRICAL CHARACTERISTICS	3
V. INTERNAL ALPHA SOURCE	4
VI. TYPICAL SPECTRUM FROM ²⁵² CF NEUTRONS.....	5
VII. TYPICAL OPERATION OF THE INSTRUMENT	5
VIII. DATA REDUCTION METHODS	6
IX. REFERENCES	6

I. INTRODUCTION

The instrument, as shown in Figure One, is a spherical tissue equivalent proportional counter; it is usually filled with tissue equivalent gas at a reduced pressure. An aluminum shell is used as a vacuum tight container for the sphere and is mounted on an aluminum stem. This allows the sphere to be placed below the surface of a tissue equivalent fluid phantom.

The instrument is generally used to accumulate a pulse height spectrum proportional to the energy deposited in the sensitive volume. This spectrum may then be transformed into a distribution of absorbed dose in LET with the aid of computer processing (or, at less convenience, by hand).

Simple electronic processing of the pulse height data as it is accumulated can also be used to allow measurement of exposures in Rads-tissue directly. This technique involves scaling of the oscillator pulses in the common Wilkinson type ADC used in most analyzers.

II. PHYSICAL CHARACTERISTICS OF THE INSTRUMENT

The detector is a spherical cavity in tissue equivalent plastic (Shonka Type A-150)^{1,2} with a 0.50 inch (1.27 cm) internal diameter. An aluminum can surrounds the TE plastic that provides electrostatic shielding and serves as a vacuum tight container. The aluminum is 0.007 inch (0.018 cm) thick. A line drawing is shown in *Figure 1*.

The sphere end may be immersed in tissue equivalent fluids, water, or other liquids that will not attack the epoxy used as a vacuum sealant. The instrument should not be left immersed in fluid while not in use. Also wiping the housing dry after use will extend its life. Good practice in eliminating possible galvanic action should be employed; for example, the fluid should be grounded separately. The connector block is not waterproof, but gaskets have been used to prevent serious moisture problems. The connector block is sturdy and was designed to be used as a clamping fixture.

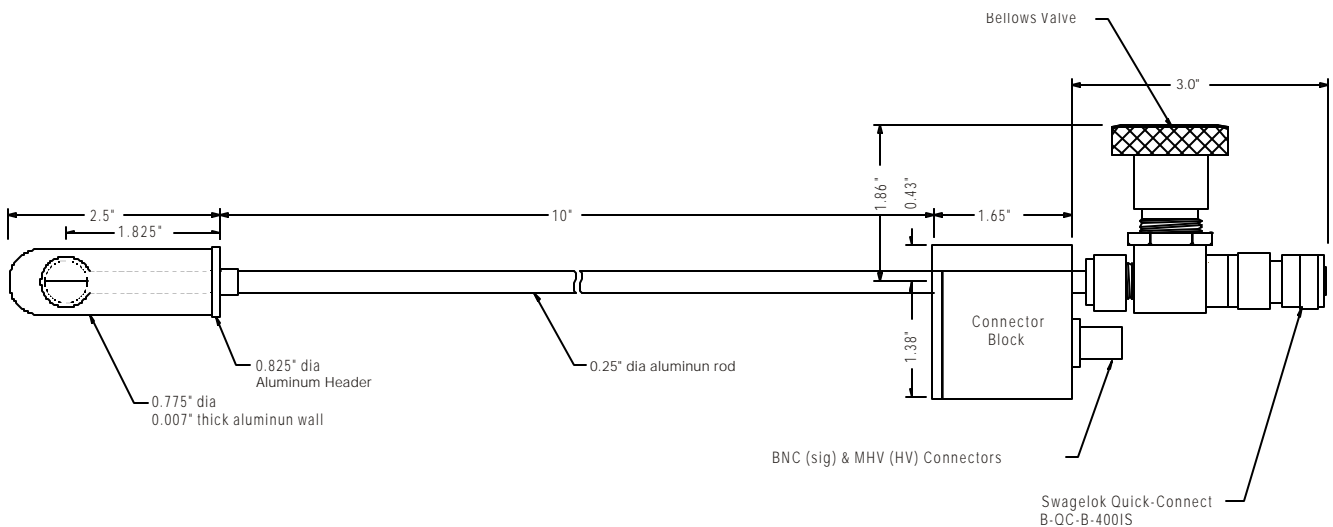

Figure 1 Diagram for LET-1/2 Counter

III. FILLING THE INSTRUMENT WITH GAS

The standard instrument is provided with a so-called Quick-Connect manufactured by Crawford Fitting Company. This connector mates with a Swagelok B-QC4-D-400 DESO-type connector. These connectors contain spring loaded plungers that seat against elastomeric o-rings providing a gas-tight seal. Experience will allow the gas filling tube to be "snapped off" the instrument with no detectable change in instrument gain. Dirt must not be allowed to get into the Quick-Connect. It will invariably cause instrument gain shifts with time.

The usual procedure for gas filling is, initially, a pump down to 5 to 10 microns with a good quality rotary pump. Liquid nitrogen cold traps may be useful, but have not been found necessary. The instrument is then filled to about 50 cm Hg with tissue equivalent gas and pumped down to 5 to 10 microns. This procedure may be repeated if the instrument has not been in use for some time.

The instrument is next filled to the proper pressure for operation. This is determined by the tissue equivalent gas density. Our usual gas mixture is 29.9% CO₂, 2.75% N₂ and 67.54% CH₄ by volume with a density of 1.062 grams per liter at 20°C and 760 mm Hg. The instrument cavity is 0.50 inch in diameter (1.270 cm) and thus a pressure of 5.63 cm Hg will simulate a cavity of about 1 x 10⁻⁶ meter diameter in density 1.00 tissue. This effective diameter can be made smaller or larger by variation of the gas pressure. As noted in the Electrical Characteristics Section, arc-over can occur if the voltage is too high. Fortunately best resolution is obtained well below arc-over potentials. At 2 cm Hg (or 0.38 u diameter) best resolution is found at 400 volts, at 5.63 cm Hg (or 1.0 u diameter) 550 volts yields the best resolution and at 10 cm Hg (or 1.9 u diameter) 650 volts may be used. A more recent tissue equivalent gas mixture⁵ composed of 39.6% CO₂, 5.4% N₂ and 55% propane has been used with equivalent results. Addition of 10% isobutane will provide better operation at very high multiplications.

Gas purity is of considerable importance in counter operation. Poor resolution, gain or a low voltage arc-over point are evidences of gas problems. Water in the gas will invariably cause arc-over. A dew point of -40°C or lower is recommended.

IV. ELECTRICAL CHARACTERISTICS

A resistor divider network is located inside the aluminum connector block. It provides proper distribution of voltages between the central electrode, helix and outer shell. In this design the central electrode is operated at a high positive potential. This voltage is applied to the connector marked HV. For recommended voltages and gas pressures see the following chart.

Counter Diameter	Gas Pressure	Operating Volts	Arc-Over Voltage
<i>Methane Base TE</i>			
1 micron	5.63 cm Hg	550-650	750
2 micron	11.26 cm Hg	650-750	850
<i>Propane Base TE</i>			
1 micron	3.32 cm Hg	500-600	700
2 micron	6.64 cm Hg	600-700	800

Arc-overs should be avoided due to the inevitable insulator carbon tracking which occurs. This can seriously degrade the chamber performance. Large arc-overs can transfer enough charge to destroy the input FET on some preamplifiers. If a solid-state preamplifier is used, it is usually necessary to limit the rate of rise of the high voltage so that switching transients do not destroy the first amplifier stage semi-conductor. The high voltage connector mates with an MHV cable connector (UG-932 A/U or equal). RG-59U or equivalent is satisfactory for the high voltage connection.

The signal from the detector appears on the connector block marked SIG. This connector mates with BNC cable connector UG-260/U. Low noise cable such as Microdot (Malco) 250/3834-0000 should be used for best low noise performance. The cable length should be as short as possible to reduce input capacity. The detector capacity to ground is approximately 17 picofarads. The pulses produced are negative going.

The SIG connector should be connected to a low noise preamplifier. The type usually specified for cooled Ge(Li) detectors is suitable (Tennelec TC-174 or 175, or Ortec 142A or 142PC). Gain should be approximately 100 to 200 mV/MeV(Ge). The detector output is AC coupled so the preamplifier may not need an input coupling capacitor. This may result in lower noise. Removal of any protection diodes across the input FET will also lower the noise, but the rate of rise of the high voltage must be limited when turning it on or off, in this case. See *Figure 2*.

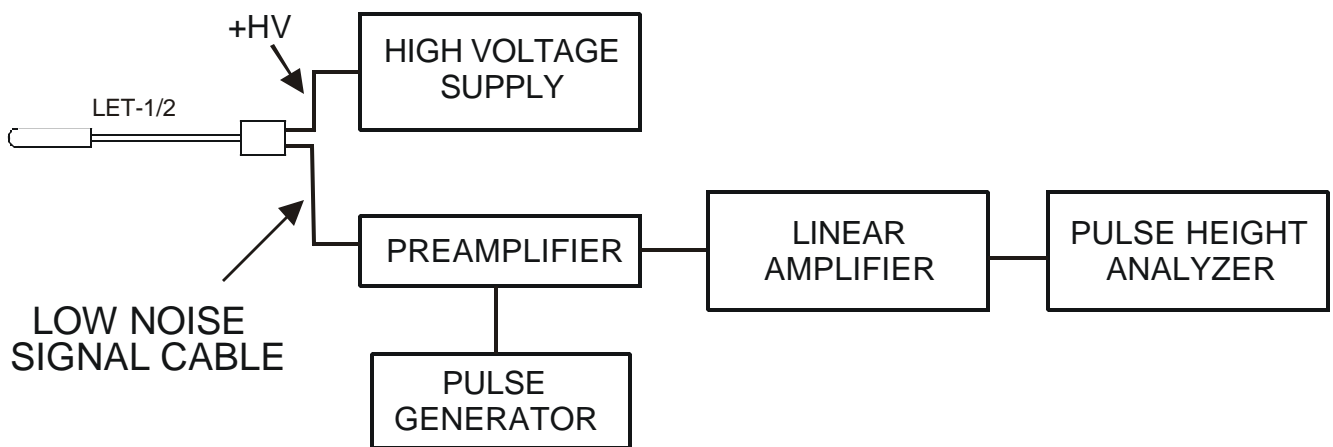

Figure 2 Electrical Interconnection Diagram for LET-1/2 Operation

V. INTERNAL ALPHA SOURCE

The detector contains a gravity operated ^{244}Cm source for gain calibration. The source is positioned so that the ^{244}Cm alpha particles can enter the sphere through a collimator when the stem is horizontal and the name-plate down. The source is "off" in other orientations, in particular when the stem is horizontal with the name-plate up and also with the stem vertical with the sphere end down. Since the source is a gravity operated device, it occasionally may be necessary to gently tap the stem to position it properly. ^{244}Cm has a mean alpha energy of 5.80 Mev which averages to 81.72 keV/u over a range of 1u ($1\text{u} = 1 \times 10^{-6}$ meters) in tissue. Because of the collimator, the source produces a peak on a multichannel pulse height analyzer. The center of this distribution is characteristic of the LET of the alpha particle averaged over the detector

diameter. Exact work can benefit from fitting a parabola to the upper half of this peak in order to find the precise position of the maximum. The alpha source resolution is relatively poor due to a compromise between source strength, collimator opening and useful count rate.

A plot is included with each detector showing the alpha peak produced by its internal source. Data are included on the graph giving the high voltage used, gain settings of the linear amplifier, gain settings of the pulse height analyzer and the gas filling pressure.

VI. TYPICAL SPECTRUM FROM ^{252}Cf NEUTRONS

Plots of the pulse height spectrum derived from a standard ^{252}Cf and from the internal ^{244}Cm are enclosed with each detector. These data were taken with standardized electronics as a quality control measure and are not representative of the best in low noise circuitry. The channel numbers written on the graph near the proton "edge" may be used to calculate resolution. These values so obtained are usually 10 to 11 percent.

VII. TYPICAL OPERATION OF THE INSTRUMENT

The instrument is initially prepared as noted in the section "Filling of the Instrument with Gas", i.e., pump-down and flushing with T.E. gas, a second pump-down and filling to the required pressure. The Quick-Connect is snapped off freeing the instrument from the gas filling apparatus. The signal and high voltage cables are then connected (using low noise cable in the signal lead). The high voltage power supply is adjusted to provide +550-650 volts if the detector has an effective diameter of 1 micron. The signal from the preamplifier and through the linear amplifier is presented to a pulse height analyzer. The instrument is positioned to turn on the alpha source. The system gain is then adjusted to place the alpha peak in a convenient channel in the pulse height analyzer. For example, at an effective diameter of 1 micron, the average LET of the ^{244}Cm alpha particles is 81.72 keV/u and if the peak is placed near channel 82, then the analyzer display is approximately 1 keV/u per channel.

After this preliminary work, an alpha spectrum is accumulated. Data should be accumulated for at least 10 minutes or more so that the position of the peak may be accurately determined. The alpha source is then turned off and the instrument positioned for data taking. Data are usually accumulated at several gain settings so that the limited dynamic range of the pulse height analyzer does not restrict the results. For example, the first run might be from about 40 to 400 keV/u (for the 400 channel analyzer). The second from 6 to 60 keV/u, the third from 1 to 10 and the fourth from noise up to 3 keV/u. This scheme allows overlap between the various segments so that they may be fitted together accurately. Obviously analyzer non-linearities must be known, as well as the precise gain shifts used to select the spectrum segments. We have used a sliding pulse generator to advantage in determining the analyzer non-linearities. A simple very stable mercury pulser can be used to measure the overall gain at the different settings.

After the data are accumulated it is good practice to take a noise spectrum for the highest gain segment. This will allow subtraction of the electronically produced noise and usually allows good data to be obtained down to about 0.5 keV/u. A second alpha spectrum should also be taken to establish detector drift characteristics, if any. Usually the detector can be expected to drift less than 1 channel out of 100 in 8 hours. Drift rates greater than this generally can be traced to gas leakage, either through pinholes or occasionally to the Quick-Connect, if a bellows valve has not been used. Since the latter is a o-ring sealed device a bit of dirt may allow some gas leakage.

This can be cured in most cases by repeated operation of the Quick-Connect. Temperature changes can also cause gain shifts.

VIII. DATA REDUCTION METHODS

Some methods of data reduction are discussed in References 6, 7, 8, and 9. Invariably, computer aided processing is required because of the large number of data points gathered. Smoothing of the data before processing may also be helpful, both linear and quadratic smoothing have been used with success.

If only certain segments of the data are needed initially a simple program can usually be written for one of the many programmable calculators now on the market. Such a program must include a smoothing routine if it is to be satisfactory.

IX. REFERENCES

1. F. R. Shonka, J. E. Rose and G. Failla, "Conducting Plastic Equivalent to tissue, Air and Polystyrene", A/Conf. 15/p/753, Second United Nations International Conference on Peaceful Uses of Atomic Energy, June, 1958.
2. J. B. Smathers, et al, October 1975, submitted to Medical Physics. A-150 composition given as H 10.2 +.1, C 76.8 +.5, O 5.9 +.2, N 3.6 +.2, Ca 1.8 +.1 and F 1.7 +.1 weight percent.
3. P. W. Benjamin, C. D. Kemshall and J. Redfern, "A High Resolution Spherical Proportional Counter", Nuclear Instruments and Methods, 59, 77 (1968).
4. B. Day, "A Portable LET Spectrometry System for the Calibration of the Concorde Radiation Meter", AWRE 057/69, Avg 1909.
5. D. Srdoc, "Experimental Technique of Measurement of Microscopic Energy Distribution in Irradiated Matter Using Rossi Counters", Radiation Research, 43, 302 (1970).
6. H. H. Rossi and W. Rosenzweig, "A Device for the Measurement of Dose as a Function of Specific Ionization", Radiology, 64, 404 (1955).
7. H. H. Rossi and W. Rosenzweig, "Measurements of Neutron Dose as a Function of Linear Energy Transfer", Radiation Research, 2, 417 (1955).
8. H. H. Rossi, Chapter 2 in F. H. Attix and W. C. Roesch, Radiation Dosimetry, Volume 1, Second Edition, Academic Press, New York and London, 1968.
9. W. H. Grant, III, G. D. Oliver Jr, and B. A. Mitchel Jr., Health Phys. 22, 351 (1972).