

MODEL 3020

MULTIFUNCTION SURVEY METER

MANUAL

June 1990

Health Physics Instruments
330 D South Kellogg Ave
Goleta, CA 93117
Tel 805.964.3615
FAX 805.964.3162

Division of Far West Technology

TABLE OF CONTENTS

SPECIFICATIONS	3
INTRODUCTION	4
OPERATION	5
FUNCTIONS	5
MODE SWITCH.....	5
DISPLAY SWITCH.....	6
SPEAKER.....	7
DISPLAY.....	7
ALARMS.....	7
SETTING THE ALARM LEVELS.....	8
MAINTENANCE AND ADJUSTMENT	8
BATTERY CHANGE	8
CALIBRATION.....	8
HIGH VOLTAGE	9
ACCESSORIES	9
EXAMPLES	10
USE HINTS.....	11

CAUTION

THE THIN WINDOW GM DETECTOR BEHIND THE SCREEN ON THE PROBE IS EASILY BROKEN. THIS DETECTOR IS EXPENSIVE. CARELESS HANDLING WILL RESULT IN UNNECESSARY EXPENSE OF BUYING A NEW GM DETECTOR.

SPECIFICATIONS

Mechanical

Dimensions: L 5.5"(14), W 2"(5.1), D 4.5"(11.5)
Weight: 1.4 lbs (0.62 kg).
Case: Drawn AL, 0.042"(.107). Panel: Al, 0.25"(.63).

Readout

Display: 4 1/2 digit LCD, 0.4" with + . : and LO BAT
Earphone signal: 2200 Hz, 5 volts, 100 ohms, 0.2 mA max.
Battery Check: LO BAT at 4.9V. Hrs. remaining: 20.
Update Time: mR/h: 2.4s, CPMx100: 0.6s, others 0.12s.

Markings and Functions

MODE switch: OFF: power off. HOLD displays last data and resets display and timer when turned to ON. ON is normal operating mode. SPKR is ON with speaker. LT is ON with speaker and light. RESET is same as HOLD but can be used to synchronize the mR display and alarm.

DISPLAY switch: mR/h displays dose rate from internal detector: 0.1-1999.9 mR/h. mR displays dose from internal detector: 0.1-1999.9 mR. CPMx100 displays 100-1999900 cpm from external probe. CNT displays total counts from external probe as a scaler. MIN .1 displays 1-19999 counts from external probe for .1 min. MIN 1 displays 1-19999 counts from external probe for 1 min.

Alarm Levels: Internally set:

mR/h alarm: 2.5, 5, 12, 25, 50, 110, 225, 450. Non latching.
mR alarm: 1.6, 3.2, 6.4, 12.8, 25.6, 51.2, 102.4, 204.8, 409.6, 8128 Latching.

Speaker: Piezo electric, 2200 Hz.

Batteries: 4 AA cells. Operating voltage: 4.5 to 6.3 v. Current drain @ 5.5v: max 5 mA, typ 3.5 mA at < 0.1 mR/h. Life: 285 hours with alkaline batteries, 210 hours with carbon-zinc batteries continuous operation.

Warm up time: 3 seconds.

System Accuracy

mR/h Range: statistical average settable to within + 3%
mR Range: statistical average settable to within + 5%

Energy Dependence

(Reading/True dose rate): 32 KeV: 0.21, 46 KeV: 0.40, 72KeV: 1.01, 120 KeV: 0.8, 180 KeV: 0.89, Co-60: 1.0. Measured with heavily filtered xrays and Co-60.

Temperature Dependence: Max 0.38% / °C, typ 0.09% / °C.

Range -20 to +50 °C. Storage range: -20 to +55 °C.

Humidity Dependence: 0-100% condensing with cap on EXT INPUT.

Rate Limitations : mR/h range: reads off scale at 10 R/h.

mR range: 3 R/h. EXT INPUT: >2 MHz.

Angular Dependence : 20% front to back 360 degrees, 20% top to bottom 270 degrees.

Internal Detector

Energy compensated GM counter. Eff Dia: 0.25"x.29".

External input sensitivity : <2 MHz at 50 mV.

Accessories :

Probes: Thin wall GM probe with 3' RG58C/U cable with BNC connectors. 30 to 45 mg/cm² SS wall.

Pancake GM probe with 3' RG58C/U Cable with BNC
Probe holder, Strap, Belt Clip, Batt. charger, Earphone

SPECIFICATIONS SUBJECT TO CHANGE WITHOUT NOTICE.

INTRODUCTION

The Model 3020 Multifunction Survey Meter combines the functions of several different measurement instruments in one small instrument. The Model 3020 offers a range of functions that no other survey meter can equal.

The multiple functions of the 3020 are useful for anyone involved with radiation. No matter whether it's surveying for contamination, checking exposure levels, taking smears, or limiting exposure to an individual we can all identify the different instruments which we would normally use. The significance of the Model 3020 is that it overcomes the limitations of any one instrument by combining all these functions together, and lets almost anyone enjoy the advantages of one multifunction instrument.

The four main functions of the instrument are:

1. Dose and Doserate Measurements

Using the internal detector the instrument will measure mR/h or mR. The mR/h range works like any normal survey meter with the exception that there is no range changing over the 4 1/2 decade range. The mR range works as an integrator similar to a pocket chamber or personnel monitor.

2. Count rate meter

If an external pancake or thin wall probe is plugged in, the 3020 will measure counts/minute from 100 to 2,000,000.

3. Scaler

The 3020 has a built in scaler with two predetermined counting times of 6 seconds and 1 minute. You can also count continuously for extended counting times. A special overflow counter will permit the display to count over its maximum to further the usefulness of the scaler.

4. Alarm

There are two alarms built into the instrument. The rate and integrate alarms always are working even when the other measurements are being made. They turn on both a visual and audible warning when they are activated. There is also a beeper built into the instrument that works like a pocket beeper and beeps about every 10 Minutes. It of course can be turned off.

In the next section we will go through the operation of the instrument and present some examples of its use.

OPERATION

Your Model 3020 Multifunction Survey Meter is shipped fully assembled with batteries. To get started:

- *Turn Display to mR/h position.
- *Turn Mode to ON position.

The display should now show 000.0 ; it may take a few seconds for the display to settle after you turn it on. If it does not turn on please check/replace the batteries as described elsewhere in the manual.

You are now reading mR/h. Occasionally the display will read 000.1 or higher. This is normal and is caused by background radiation. If you have a small gamma check source bring it near the left hand back of the instrument and the reading should increase. The update time is 2.4 seconds. You can move any switch to any position at any time without damage to the instrument, although you may lose some data.

Plug the external probe (if you have one) into the EXT INPUT.

- *Turn Mode to SPKR position.
- *Turn Display to CNT position.

The display should now start to count up from the background radiation that the probe is exposed to. Move your check source closer to the probe and you will see the numbers counting up and hear each count from the speaker. Now we will take a 6 second count.

- *Turn Display to .1 MIN.
- *Turn Mode to HOLD then to SPKR.

The display should reset to zero and then begin counting up. When the 6 seconds is over the instrument will beep and the Colon in the middle of the display will turn on to show you that the count is done. The number in the display is the counts in 6 seconds.

These few simple operations should give you a feeling for operating the instrument. The following section will discuss each switch setting and function.

FUNCTIONS

In this section we will discuss the four controls and how they operate the instrument.

MODE SWITCH

The mode switch does not change what the instrument is measuring but rather how it measures it. The six positions allow you to control the operation of instrument.

Starting from the most counter clockwise position and reading clockwise;

OFF Instrument power is turned off. Power is on in all other positions.

HOLD Holds or freezes the display. Useful when using the scaler or when you want to hold a reading. Turning to this position holds the display. Turning away from this position to ON will reset the instrument except for the alarms.

ON Normal operation of instrument.

SPKR (SPEAKER) Normal operation of instrument with speaker turned on.

LT (LIGHT) Normal operation of instrument with speaker and light for display.

RESET Same operation as HOLD with the exception that it fully resets the mR range and can be used to synchronize the mR range and the mR alarm. (See section on Alarms.)

DISPLAY SWITCH

The Display switch changes what information is shown on the display. It is divided into two sections. The first two positions mR/h and mR, use an internal GM tube. The remaining four sections; CPMx100, CNT, .1MIN and 1MIN all use the external detector that is plugged into the EXT INPUT. To help you remember this division, the line around the switch is continuous for the last four positions and connects with the EXT INPUT.

Starting from the most Counter Clockwise position and reading clockwise;

mR/h Measures and displays mR/h starting at .1 mR/h.

mR Measures and displays mR starting at .1mR.

NOTE that hold does not reset the internal registers of this range to zero and may result in the first .1 mR appearing earlier than it should. RESET will reset the internal registers to zero and will result in a correct reading.

CPMx100 Measures and displays counts per minute times 100. Starts at 1 in display which is really 100 CPM.

CNT Operates as a scaler: counts up one for each event.

.1 MIN Counts for .1 minute or 6 seconds from time of last reset. Colon turns on at end of count.

1 MIN Counts for 1 minute from time of last reset. Colon turns on at end of count.

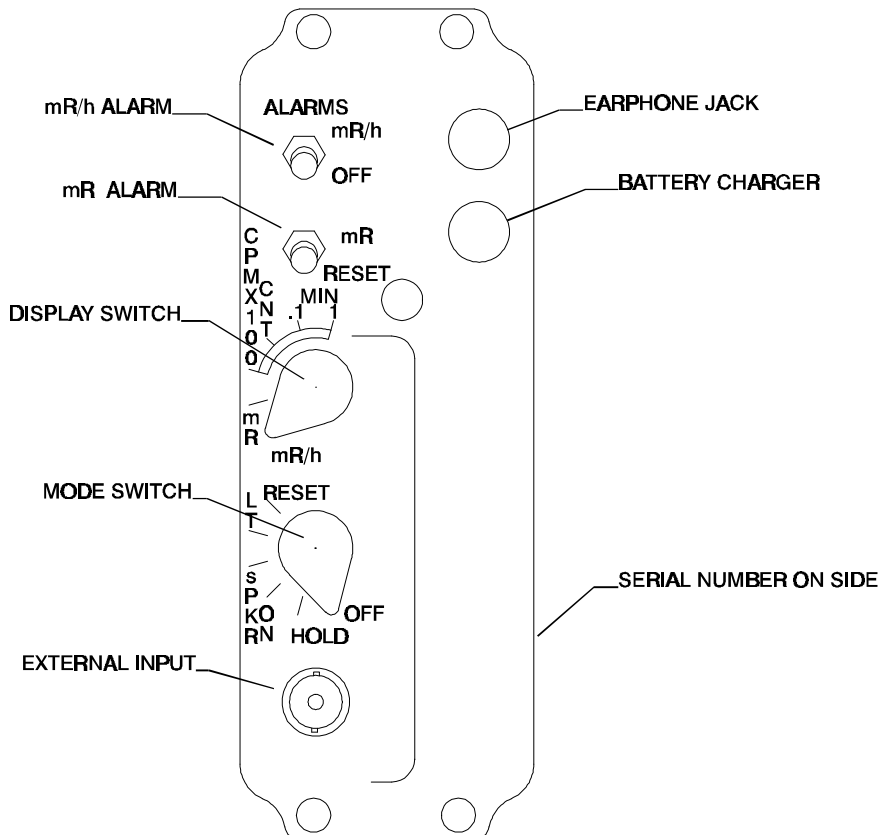

SPEAKER

The speaker indicates three different parameters depending on the setting of the Display switch. They are grouped in two's around the switch and are;

mR/h and mR Beeps every .002 mR from internal detector. Which is about every 20 minutes from background.

CPMx100 and CNT Clicks every count from external input.

.1 and 1 MIN Beeps at the end of the counting time. To tell you that it is finished. It keeps you from having to monitor the display to see when the time is up and is especially useful when you have to do many 1 minute counts. Remember the speaker must be turned on (MODE set to SPKR or LT) for these to work.

POSITION	DETECTOR	DISPLAY	BEEPER	COLON	DEC POINT
mR/h	Internal	1XXX.X mR/h	Every .002 mR	N/A	YES
mR	Internal	1XXX.X mR	Every .002 mR	N/A	YES
CPMx100	External	1XXXX counts per min x 100	Every Count	N/A	None
CNT	External	1XXXX counts	Every Count	N/A	None
0.1 Min	External	1XXXX counts in 6 seconds	At end of time	End of Time	None
1 Min	External	1XXXX counts in 60 seconds	At end of time	End of Time	None

DISPLAY

The display is a 4-1/2 digit Liquid Crystal Display (LCD). In addition to the colon and LO BAT indicators, the display incorporates a plus sign to the left of the digits. This plus sign is used to indicate over-range. If the parameter being measured exceeds 19999 (or 1999.9 on mR/h and mR ranges) the plus sign comes on. The numeric display will indicate a

number which comes from the resetting of the nines, but leaves the 1 on. In the continuous counting mode, the instrument would read 19998, 19999, +10000, +10001 etc. This feature may help retrieve data which is just over range, however twice over range gives the same display so caution is important in reading overrange data. It is useful when the instrument is used as a scaler since you can watch the display and count the times it rolls over.

ALARMS

There are two alarms built into the instrument and they are controlled by the two toggle switches at the top of the panel. The top one controls the mR/h or rate alarm and the bottom one the mR or integrate alarm.

The two toggle switches are locking levers and operate by pulling out on the handle and then moving the switch. They spring back into position when released and keep the settings from being accidentally set or bumped.

mR/h: Moving the mR/h lever to mR/h or away from OFF turns on the mR/h alarm. When the doserate reaches the alarm level, the beeper will pulse and the colon will flash. If the level increases beyond the alarm level the beeps will be longer and at about five times the alarm level the beeper will make a continuous tone and the colon will remain on.

mR: Moving the mR lever to mR or away from RESET turns on the integrating alarm. When the accumulated dose equals the alarm level, the beeper will make a continuous tone and the colon will turn on.

The accumulated dose for the alarm is lost if the instrument is turned off or if the ALARM mR switch is turned to RESET which resets the alarm. To synchronize the mR readout and the mR alarm, the display switch must be in the mR position, and the ALARM mR switch on. The MODE switch then is momentarily turned to RESET. This starts both the alarms and the display at zero at the same time and assures that they will track together. It is not necessary to do this for either the alarm or the display except if you wish to measure them together. If instead you turn the display to mR and then turn on the alarm, there may be a .1 mR difference between where the alarm turns on and where the display says it should.

Both the mR/h and mR alarms operate independently of the MODE and DISPLAY switches except for the reset noted above. If the rate exceeds the mR/h alarm level or if the accumulated dose exceeds the mR alarm level, the alarms will operate even if an external probe is being used.

SETTING THE ALARM LEVELS

Turn the instrument off and unscrew the four thumbscrews on the side panel and remove the case. The alarm levels are on the back of the instrument at the top and consist of two small red jumpers on the double row of pins. To change the setting pull the small red jumper off of the pins and insert it on the set that correspond to the new level you wish to set. The mR/h and mR are set independently.

MAINTENANCE AND ADJUSTMENT BATTERY CHANGE

The Model 3020 requires 4 AA cells. You can use any type of AA battery you can find. When the LO BAT indicator turns on in the upper left hand of the display the batteries have about 20 hours of life remaining with alkaline cells. If the beeper quits it is time to change the batteries. If you turn on the light and the batteries are poor the LO BAT indicator will turn on. Turn the instrument off and unscrew the four thumbscrews on the front panel. Slip the instrument out of its case and change the batteries observing the polarity marked on the holders.

CALIBRATION

The only user calibration is the sensitivity of the internal GM tube. If the mR/h range is calibrated, the mR range will automatically be calibrated. A dead time correction circuit is included in these ranges to compensate for counting loss due to GM counter dead time at high dose rates. The calibration is done as follows:

1. Turn the instrument off and remove it from its case.
2. Turn the MODE switch to ON and the DISPLAY switch to mR/h. Note the location of the internal detector.
3. Place a Co-60, Cs-137 or Ra-226 source so that the detector is exposed to a known dose rate of 50 to 100 mR/h.
4. Refer to the diagram below and adjust CAL so that the reading is correct.
5. Check the readings at 10 mR/h, 100 mR/h and 1000 mR/h.
6. Check the readings of the mR range using appropriate total doses. All readings should be within 15% of the known value.

No calibration is required for the external probe since all counting rates depend only on time intervals which are measured with a crystal controlled clock. Note that no dead time correction is applied to the external probe.

HIGH VOLTAGE

Although the high voltage is adjustable by changing the HV in the diagram, it is factory set at 900 V for GM tubes. The same HV supply is used for both the internal and external GM tubes and should not be changed. If it is changed the internal tube may be damaged or the mR/h calibration made invalid.

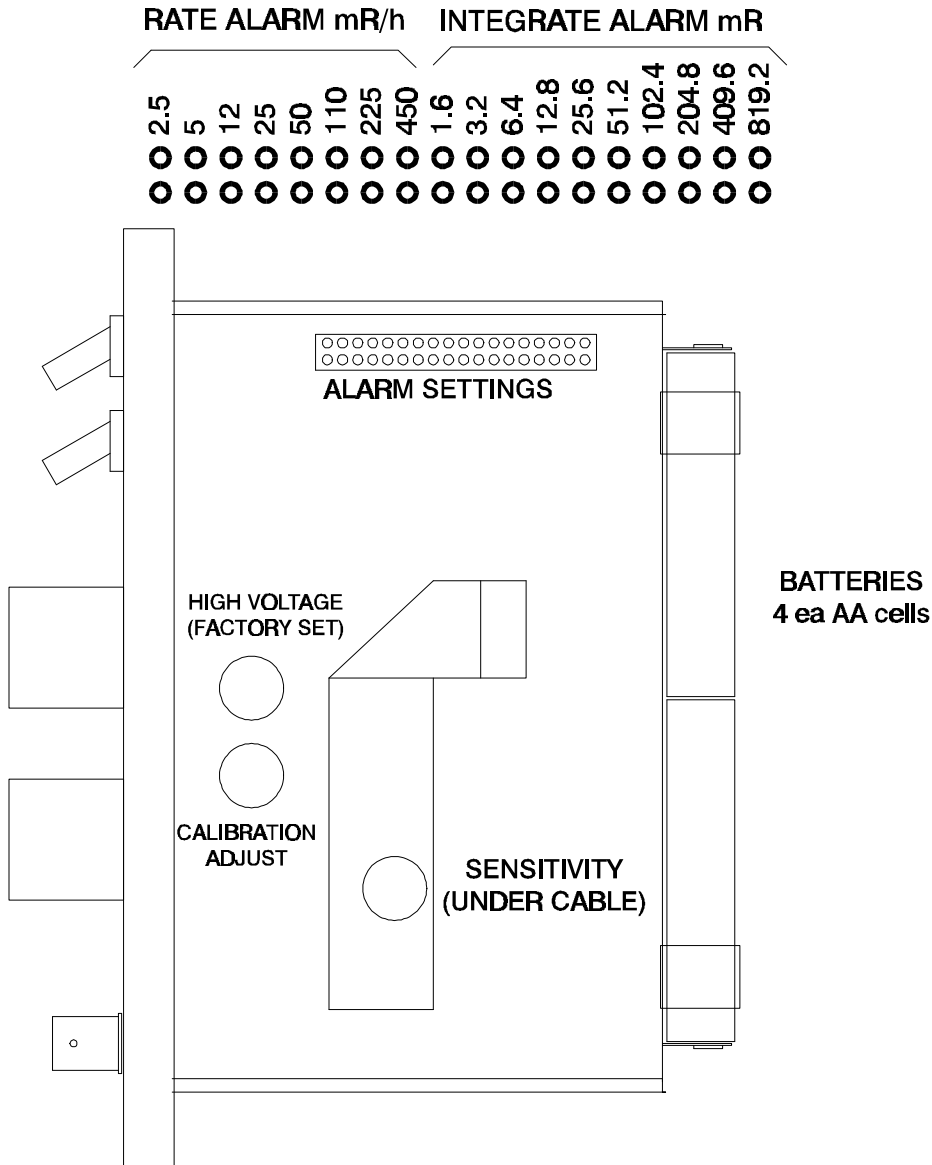

ACCESSORIES

Probe Holder : The Probe Holder mounts on the right side of the main panel with two of the thumbscrews securing the case. Both the Pancake GM Probe and the Thin Walled GM Probe snap into this holder. It also serves as a storage place for the beta shield of the Thin Walled GM Probe.

Shoulder Strap : The Shoulder Strap mounts on the case using the large mounting screws. The center section of the shoulder strap may be removed to make a carrying strap.

Belt Clip : The Belt Clip mounts on the rear of the case using the large mounting screw. If both the shoulder strap and Belt Clip are used together, the longer mounting screw is required.

Pancake GM Probe : The Pancake GM Probe uses the standard 1-3/4 inch GM counter. The handle is removeable and can be mounted at various angles. Without the handle, the probe may be attached to the back of the instrument using the large screw. This configuration makes the instrument a single unit. A short cable is available if this configuration is used extensively.

Thin walled GM Probe : The Thin Walled Probe is useful to detect low level gamma or beta fields of radiation. The beta shield is removed by loosening the thumb screw and removing the shield. The shield may be stored in the Probe Holder clip.

Earphone : To connect the earphone, remove the sealing screw and o-ring from the EAR jack and plug in the earphone. The MODE switch must be in the SPKR position however the alarms will still beep in the earphone even if the speaker is off.

Battery Charger : To connect the battery charger to instruments with rechargeable batteries, remove the sealing screw and O-ring in the BAT jack and plug in the battery charger. The charger supplies the instrument with 12 volts DC. The center of the miniature plug is positive and the shell is negative. The batteries will be fully charged in 14 hours.

Little degradation of the batteries will occur if the charger is left on continuously. Do not connect the charger to instruments with normal batteries or with no batteries or SEVERE damage will occur.

EXAMPLES

In all the following examples, the following accessories may be used: the Probe Holder, Shoulder Strap, Belt Clip, Rechargeable Batteries, and Earphones. The operational option of lighting the display is possible in all of the samples by turning the MODE switch to LT.

1. Pocket dosimeter

Required: Model 3020 Instrument with belt clip.

*MODE switch to SPKR

*DISPLAY switch to mR

The instrument displays the total dose directly in mR with the display format 1XXX.X. With the speaker on, the user can tell if he happens into a radiation area. The belt clip allows him to carry the instrument on his person rather than loose with the shoulder strap.

2. Gamma Dose Rate Meter

Required: Model 3020 Instrument and shoulder strap.

*MODE switch to ON

*DISPLAY switch to mR/h

*mR Alarm on

This configuration would be used to measure gamma rays from isotopes with energies above .08 MeV. The display is directly in mR/h with the display format 1XXX.X, giving a range from 0.1 to 2000 mR/h. The Alarm would tell the user if he was in an area too long.

3. Contamination Monitor with Pancake GM Probe

Required: Model 3020 Instrument, Pancake GM Probe, Cable, Shoulder Strap.

- *MODE switch ON
- *DISPLAY switch to CPMx100

The instrument will count and display CPM times 100 every 0.6 seconds. If the level is too low to count reliably on this range, then the scaler can be used by switching to .1 or 1 minute times. Low levels of twice background can be reliably measured this way.

4. Low Level Beta-Gamma Monitor.

Required: Basic 3020 Instrument, Thin Walled GM Probe, Cable.

- *MODE switch ON
- *DISPLAY switch to CPM X 100, CNT, 0.1 or 1 min

The instrument can be used to detect beta and gamma fields of radiation. The ratio can be obtained by a measurement with and without the shield.

An EMERGENCY ready-for-anything instrument can be configured by using the thin wall probe and the belt clip. The cord will wrap around the GM tube and the instrument can be worn on the belt much like portable 2-way radios. Almost any situation could be handled with this instrument from smears to accident level personnel monitoring.

USE HINTS

Do not use the 3020 in high xray fields. Most xray machines produce pulsed radiation which will result in inaccurate dose measurements.

If the instrument is being operated in the mR mode, plugging in or unplugging an external probe may throw in a few mR's.

To locate sources of radiation with a probe, use the CNT display. This way you don't have to read numbers just look at how fast the digits flash. Low dose rates will make the units place flash. As the radiation gets higher and higher, the tens, then hundreds, then thousands place will flash and the lower decades will just be a blur. Its amazing how much

faster you can find hot spots this way than with a meter.

You can count samples for extended times in the field by using the CNT display and timing the counting period. Switching the MODE switch to HOLD, stops the count and holds the display. Switching to ON, resets the display to zero and starts the next count.

The Model 3020 can be used alone as a temporary area monitor by using the mR/h display and the SPKR on. An audible beep is produced every .0027 mR. The mR/h alarm can also be used for this purpose.

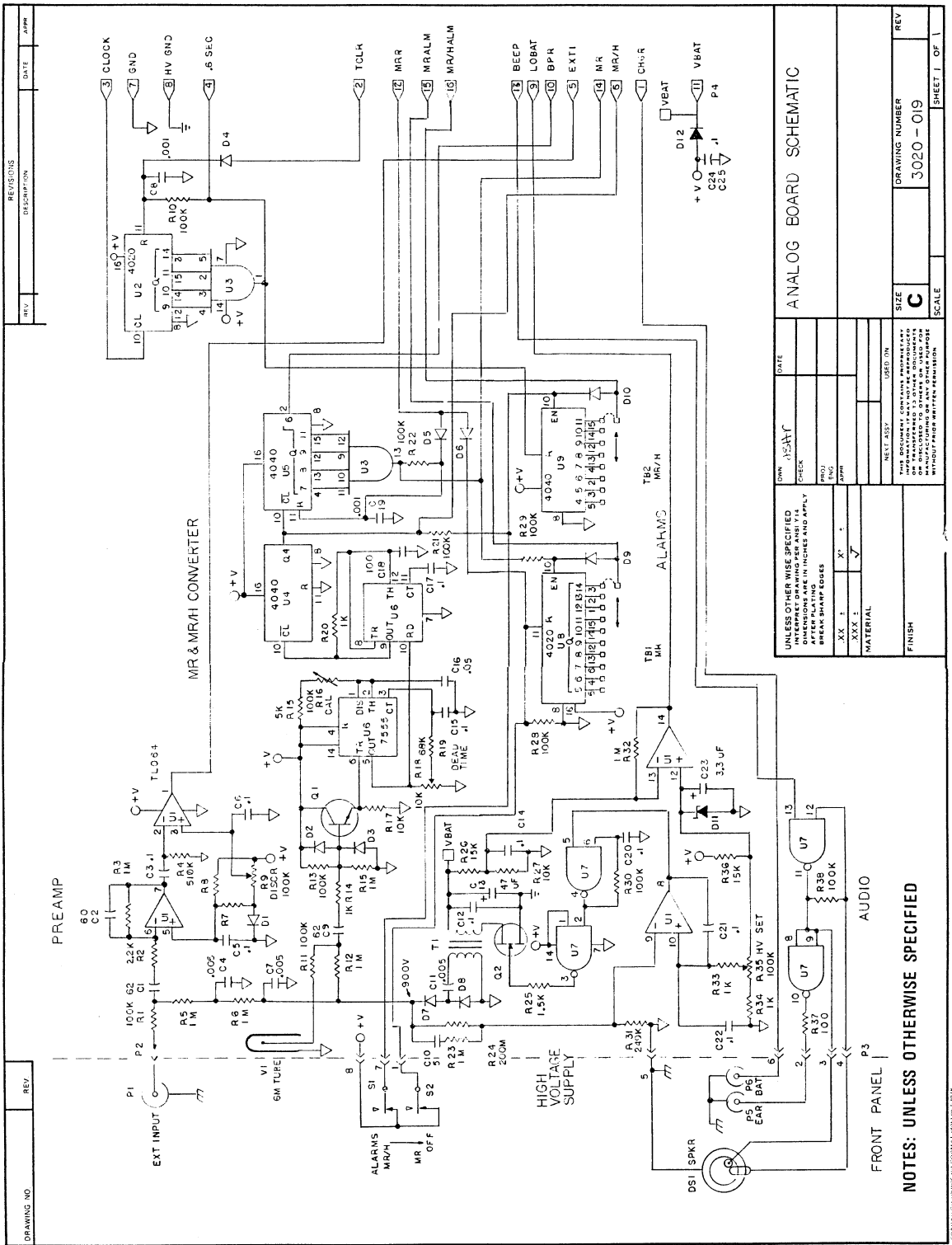

REV	DESCRIPTION	DATE	APPN

DRAWING NO	REV

ANALOG BOARD SCHEMATIC

DATE	DESIGNER	CHECKER	PROJ. NO.	APPN. NO.	SCALE

UNLESS OTHERWISE SPECIFIED	UNLESS OTHERWISE SPECIFIED
ALL DIMENSIONS ARE IN INCHES AND APPLY TO BREAK SHARP EDGES	ALL DIMENSIONS ARE IN INCHES AND APPLY TO BREAK SHARP EDGES
XX 1	XX 2
MATERIAL	FINISH

NOTES: UNLESS OTHERWISE SPECIFIED

SIZE	DRAWING NUMBER	REV
C	3020-019	1

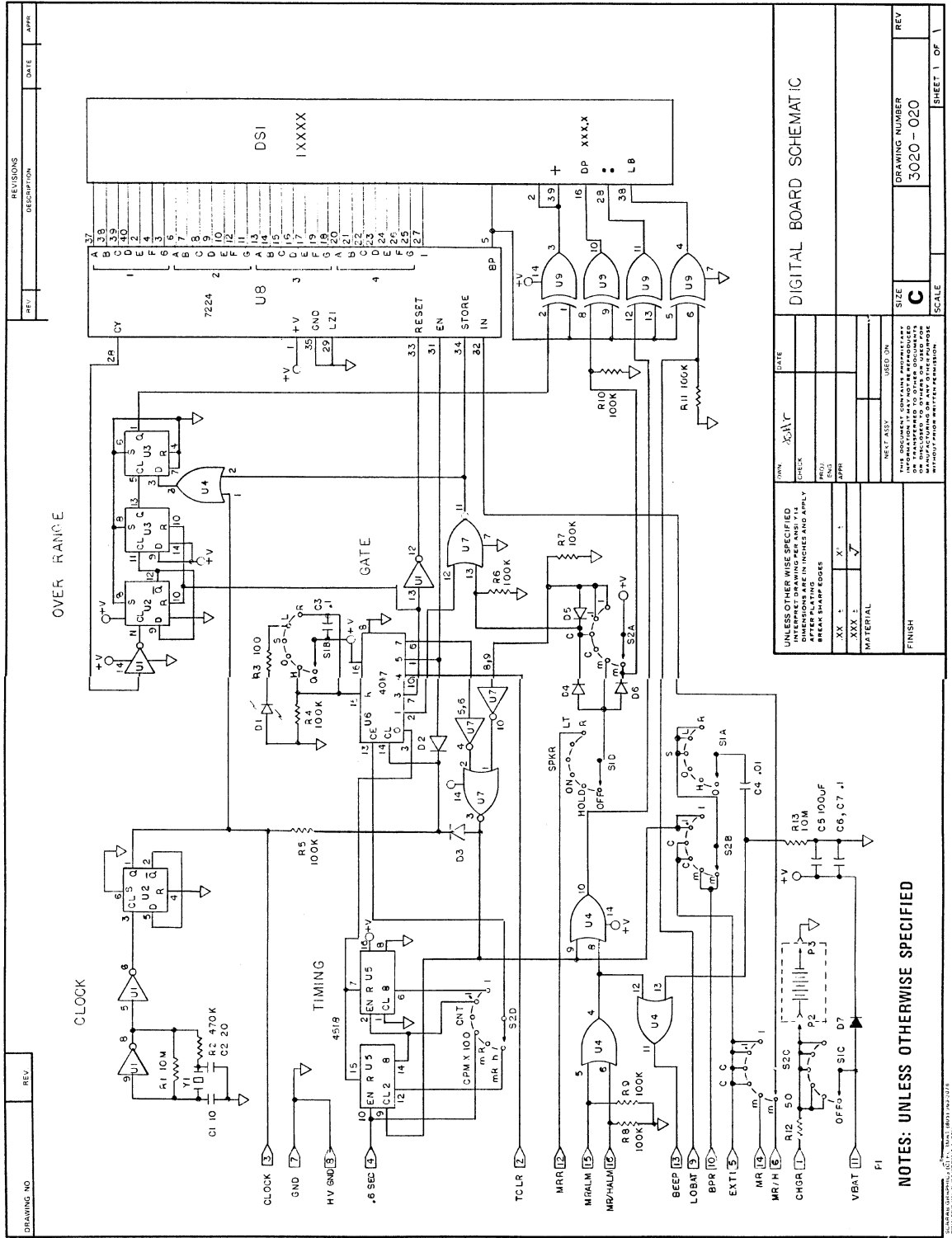

REV	DESCRIPTION	DATE	APPR

OWN	ASAT	DATE	
CHECK			
PROJ			
APPN			
XX	X		
XXX			
MATERIAL			
FINISH			

NET ASY	USED ON

UNLESS OTHERWISE SPECIFIED
 INTERPRET DRAWING PER ANSI Y14
 BREAK SHARP EDGES
 XX : ✓
 XXX :

THIS DOCUMENT CONTAINS PROPRIETARY
 INFORMATION. IT IS TO BE KEPT
 CONFIDENTIAL AND NOT TO BE
 REPRODUCED OR TRANSMITTED IN ANY
 MANNER WITHOUT THE WRITTEN
 PERMISSION OF THE COMPANY.

DIGITAL BOARD SCHEMATIC

SCALE: **C**

DRAWING NUMBER: **3020-020**

REV: **1**

SHEET **1** OF **1**

NOTES: UNLESS OTHERWISE SPECIFIED